



PDW 9mm SBR Series Instruction Manual

Please read through all instructions before operating the rifle.



⚠ WARNING

- User of this airsoft rifle must be 18 years of age or older.
- The shooting range of the plastic BB bullet can reach up to 100 meters, beware at all time. Careless shooting may cause eyes or other injuries.
- Read through this Handling and Instruction Manual carefully before operating this Airsoft Gun.

WARNING

Please read through this Manual carefully before operating this gun.

This sport gun is developed for recreational use and it is capable to shoot BB bullets as a projectile so please be caution when handling or using this gun. Please pay special attention for safe operation and remember the warnings and be cautions at all times. Careless shooting or improper use is dangerous, and it can cause damage or injury on human or animal.

Operating this sport gun must be aged over 18 years old. Users must understand and follow the laws of country before possessing or operating this product.



Always wear eyes protective gear.

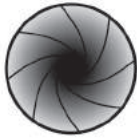

NEVER look into the gun muzzle.



NEVER point the gun or to shoot towards a person or an animal.



Store the airsoft gun at places out of reach by children.



Always put the gun in a case or bag when you are carrying it.



Always put your finger away from the trigger except you are ready to fire the gun.



Set selector lever at the "SAFE" position, and remove the magazine when the rifle is not in use.



Even if the magazine is removed, there might be remaining BB bullet in the gun which still can be shooting.



Use only the designated battery charger to charge battery.
Do NOT use battery which is swell-up or damaged.
Do NOT expose battery to water or fire.
Do NOT drop, throw or bend the battery.
Do NOT expose the battery to extreme high or low temperatures.



Specification

Suggested Energy Source	: 9.6V Battery
Overall Length	: 722mm
Inner Barrel Length	: 305mm
Weight without Magazine	: 2005g
Main Material	: Zinc Alloy; Nylon Fiber
Major Color	: Black / Gun Metal Grey / Dark Earth / Black & Red / Black & Blue
Capacity	: 100 Rds
Caliber	: 6mm
Fire Mode	: Safe / Single / Full-Auto
Marking	: King Arms
Loading Mode	: Automatic
Outer Barrel Design	: Flexible & Light Weight Design
Hop-Up Bucking Design	: Adjustable AEG Type
Muzzle Velocity (Canada version)	: Over 366 FPS
Muzzle Velocity (Italy / Japan version)	: Lower than 0.98J
Muzzle Velocity (Standard version)	: 380~420 FPS

Charging The Battery

- Charge the battery every time before operating the gun. (Battery and charger sold separately except Field Package)
- Always treat your battery with care, do not attempt to disassemble or modify the battery or alter the cord or plug.
- Use the specified battery for the gun and avoiding use of non-standard battery or the original designed functions may not be working.
- Make sure the battery is in good shape before charging. Use the specified battery charger which is applicable to the above battery. Never charge the battery if it is damaged and stop charging when battery is overheat.
- Only use the correct battery and charger. King Arms would not responsible and liable for any accidents, losses or damages whatsoever caused by improper or incorrect usage of battery.

Component Names : KA-AG-220



Overall Length : 621mm
Inner Barrel Length : 180mm
Weight without Magazine : 1975g

Component Names : KA-AG-229



Overall Length : 530mm
Inner Barrel Length : 135mm
Weight without Magazine : 1745g

Component Names : KA-AG-231



Overall Length : 621mm
Inner Barrel Length : 195mm
Weight without Magazine : 1920g

Selector Lever & Safety Setting

WARNING

To prevent malfunction, please do not adjust the selector lever from semi to full auto while pulling the trigger.

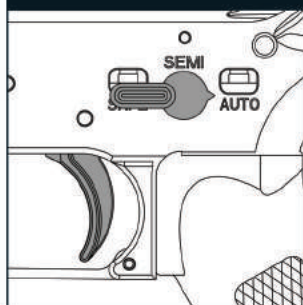

CAUTION: Set the selector lever correctly in position; otherwise, malfunction may occur.

Safety Setting

Always set the lever to the SAFE position and attach the protective cap when you are not firing the gun or during storage.

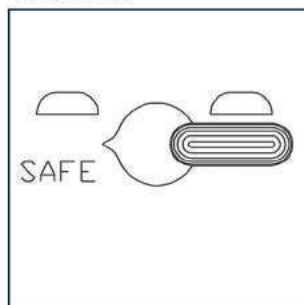

Semi Auto (Single Shot)

The gun will fire one shot each time when the trigger is pulled.

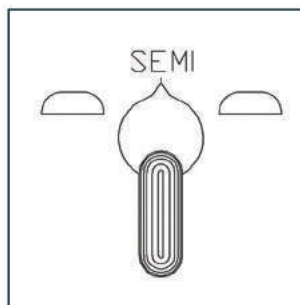

Full Auto (Automatic Firing)

The gun will fire automatically while the trigger remains pulled.

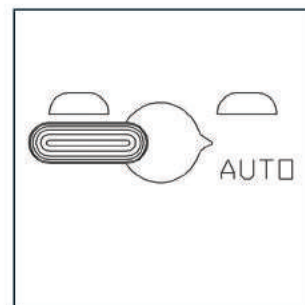

Installing The Battery



1. Pull the stock till the very end.

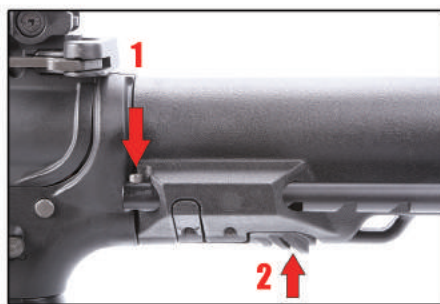

2. Press the bolt and the stock adjust button at the same time, then pull back the stock.

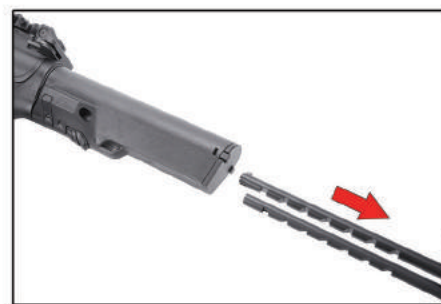

3. Pull back the stock and remove it.



4. After remove the stock, press the button at both sides of the stock cap to open it.



5. Plug in the appropriate battery.



6. Close the stock cap.



7. Align the stock at the right position with the holes, press the bolt and the stock adjust button at the same time, then push ahead.



8. Push ahead till the bolt bounce back and the stock will be reset.

Firing The Rifle

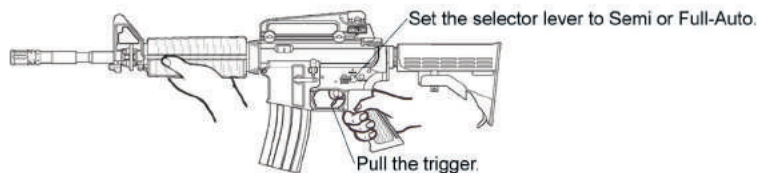

- Change the battery if the fire-rate becomes slow.
- It is normal that a blank fire may occur at the first shot even if the gun is loaded.
- It is normal that some smell may be generated from the motor for a while when a new gun is operating.
- It is normal that the hop-up function may be unstable for the first couple rounds after silicone oil has been applied on hop-up unit.
- It may be possible that the trigger cannot be pulled in "Semi" mode as the cut-off lever inside the gearbox is activated, user can fire 1-3 seconds in "Auto" mode to solve this problem.

⚠ WARNING ⚠

- Make sure you followed all safety instructions before firing the gun.
- Remove the protective cap only when you are ready to fire.
- After firing about 500 bullets, rest the gun for 5 to 10 minutes.
- Always attach the protective cap and set the selector lever to Safety position when the air gun not ready to fire.

Hop-up Adjustment



- Turning the hop-up adjustment dial excessively can cause bullet clogging. Keep pulling the trigger while bullet being clogged will damage the gun.
- Stop firing the gun immediately if bullet clogging occurs. Rotate the hop-up adjustment dial to the "Normal" position and remove the clogging bullets using a clearing rod.
- Make sure to rotate the hop-up adjustment dial to the "Normal" position while removing the clogged bullets, otherwise the chamber unit may be damaged.
- Never use dirty or used bullets as dirty chamber will result in unstable hop up.
- Lacking or over spraying of silicone oil will also lead to unstable hop up.

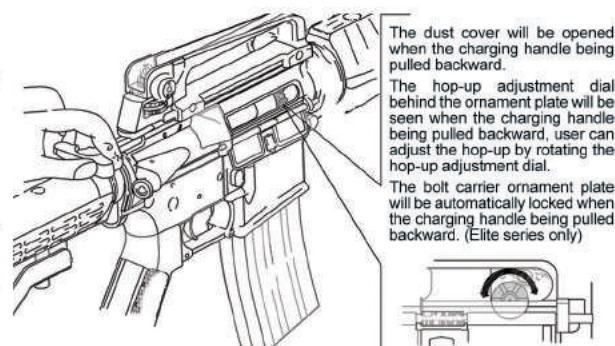

Excessive hop-up:
Turn the dial clockwise.

Insufficient hop-up:
Turn the dial anti-clockwise.

Maintenance

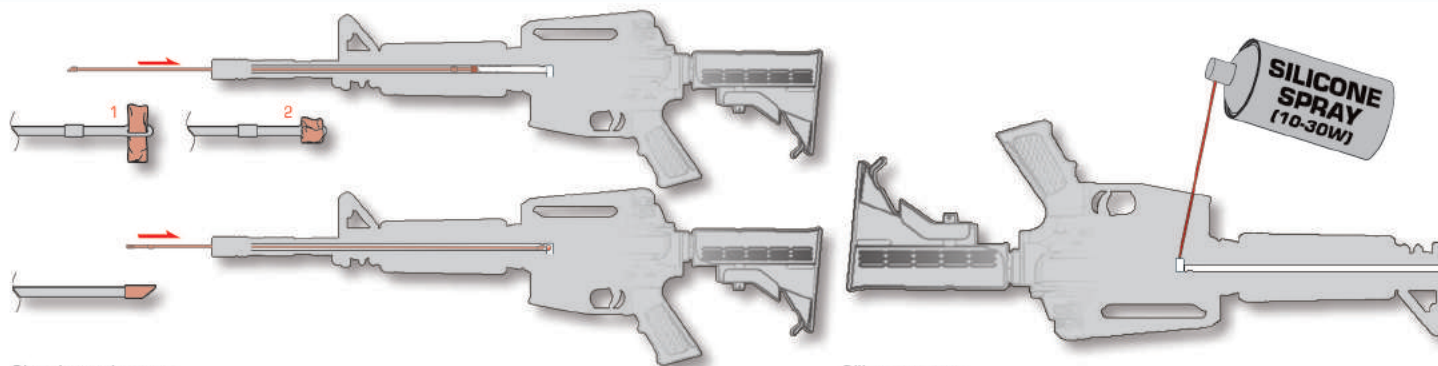

Cleaning rod usage:

User can use a cleaning rod to clean the inner barrel, there is a hole on one end and user can place a piece of cleaning cloth and slide it in the inner barrel to clean the barrel. On the other end, there is a plastic tip for user to push the jammed BB out from the inner barrel.

Silicone spray:

Apply some silicone oil onto moving parts and also into the BBs feeding tube (where the BBs are fed up into the hop-up unit). Be noticed that do not use WD40 or real gun oil since they might be corrosive and cause damage to the parts of your gun.

Gearbox spring tension releasing:

After the shooting process, the piston inside the gearbox might not be able to finish the entire shooting cycle and will be stopped in the middle. This will cause the spring to constantly being compressed and hence the shooting power will be decrease in long run. Therefore, to ensure the piston to finish the entire shooting cycle and able to release the spring tension is important for the gearbox to be maintain in its best working condition. The easiest way to avoid this issue is to dry-fire 3-5 shots in semi-auto to let the piston to complete its cycle.

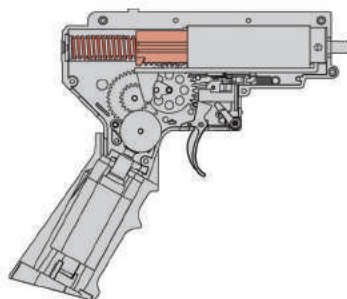

In this situation, the piston is stopped in the middle of the shooting cycle. The spring is now being compressed and it will cause damage to the spring in long run.

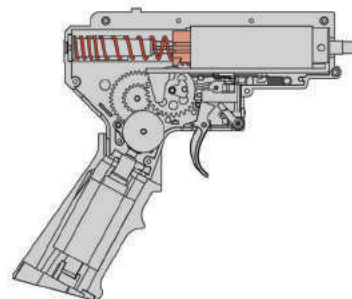

After dry-firing 3-5 shots in semi-auto mode, the piston will complete the shooting cycle and going back to the original position therefore the spring is not being compressed.

ATTENTION!

Please make sure the screw is fastened in the stock tube before use.



1. Remove the stock. Remove the screw with a Phillips head screwdriver in the stock tube.



2. Take off the parts in this order as the indication.



3. Choose the right tool according to the spring guide.



4. Press down the spring guide with a flathead screwdriver and turn 90°. Caution! The rebound while turning the screwdriver might be dangerous.

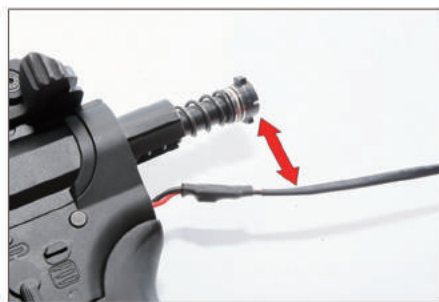

5. Mind the distance between the wire, it may damage the wire due to the rebound.



6. Take off the original spring and the spring guide.



7. Replace with desired spring, and install with the spring guide.



8. Press down the spring guide again with a flathead screwdriver, and fix the spring and the spring guide by turning the spring guide 90°. Caution! The rebound while turning the screw driver might be dangerous.



9. Put the parts back in order.



10. Do not damage the wire.



11. Fasten the screw with a Phillips head screwdriver.



12. Reinstall the stock, and the customization has been completed!

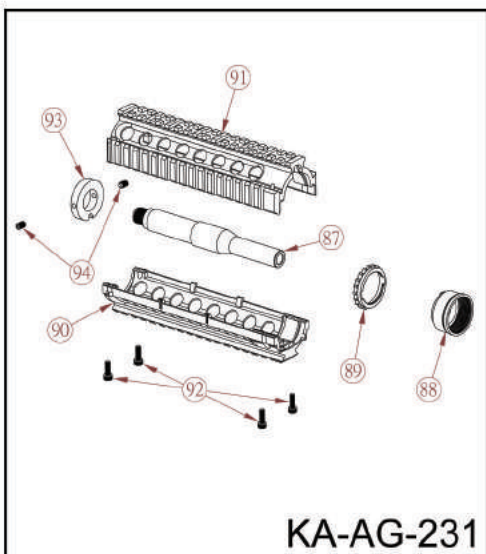
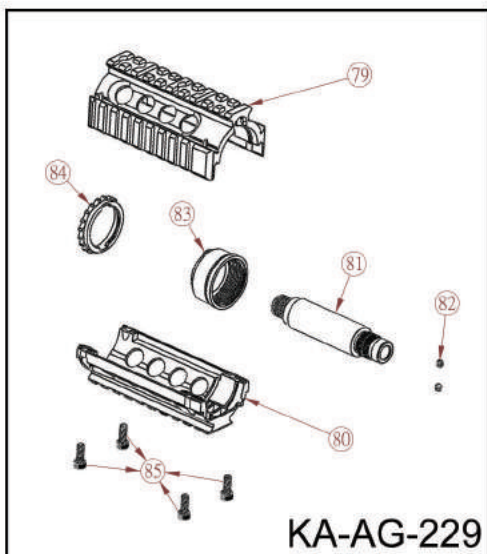
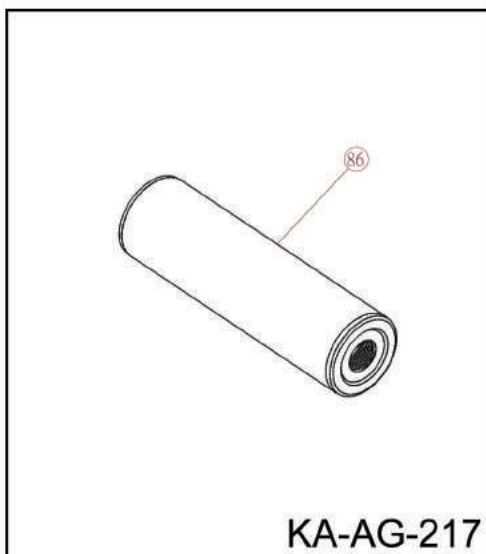
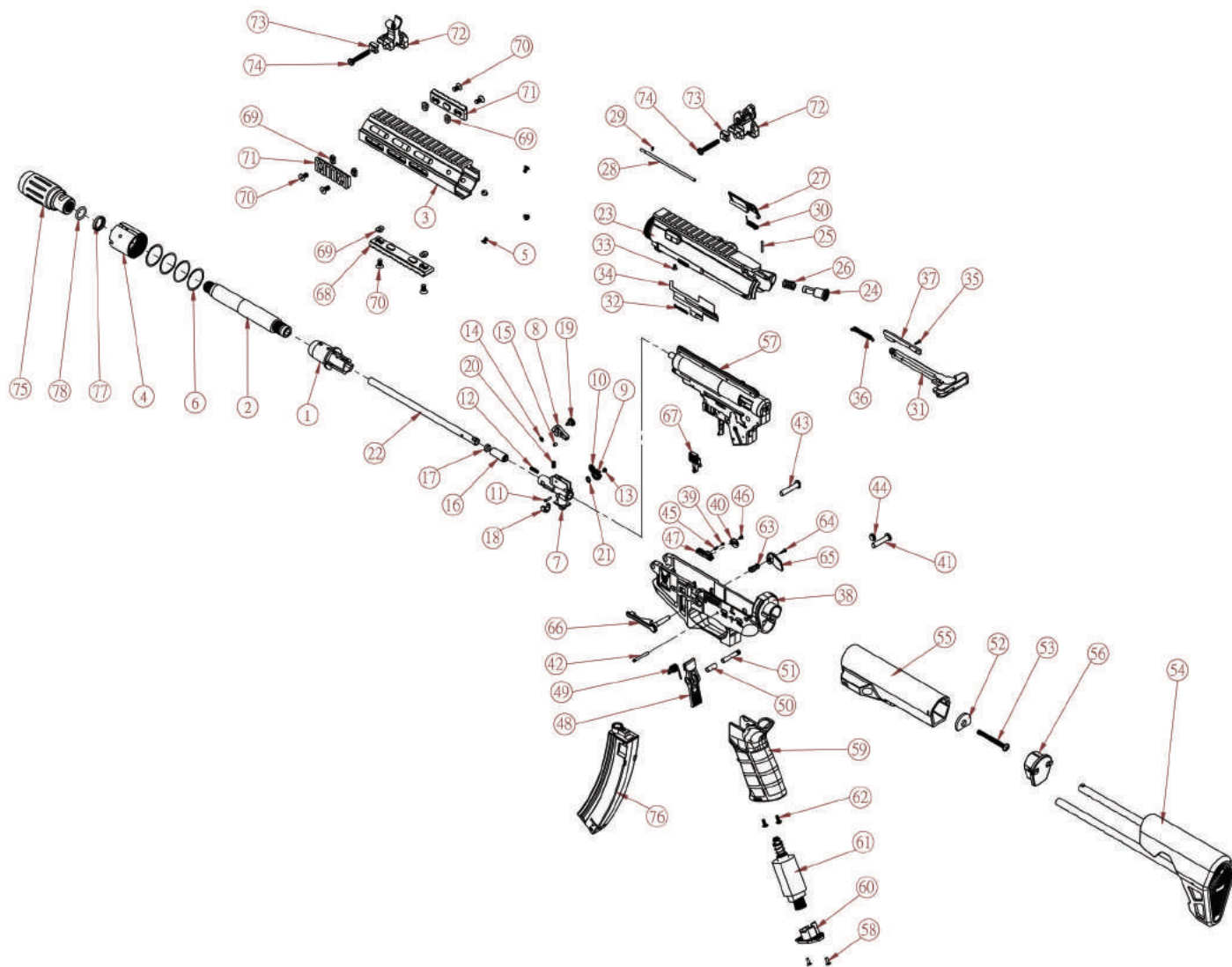

Explosive Diagram

編號	零件名稱	數量	編號	零件名稱	數量	
1	AG-120-04-A01	1	72	FS-13-01-BK-A01	2	
2	OB-08-A02	KA-AG-220	73	FS-13-02-BK-A01	2	
3	RAS-75-01-A03	KA-AG-220	74	SCR-ST-1M5X32-A01	2	
4	RAS-70-02-A02	KA-AG-220	75	FH-52-03-A01	1	
5	SCR-HE-3M4X6-A01	KA-AG-220	76	MAGP-171L-A01	1	
6	OBK-0-A01	KA-AG-220	77	AG-120-06-A01	1	
7	AG-63-30-A01	1	78	OR-13D2X2D4-A01	1	
8	AG-63-32-A01	1	79	RAS-51-01-BK-A01	KA-AG-229	1
9	AG-63-33-A01	1	80	RAS-51-02-BK-A01	KA-AG-229	1
10	AG-63-34-A01	1	81	OB-09-A02	KA-AG-229	1
11	PI-22-C-A01	1	82	SCR-HE-0-M4X4-A01	KA-AG-229	2
12	S-R-77-A01	1	83	AG-119-39-A01	KA-AG-229	1
13	SCR-CR-3M2X3D5-A01	1	84	AG-119-40-A01	KA-AG-229	1
14	M4-16-11-A01	1	85	SCR-HE-2M4X12-A01	KA-AG-229	4
15	W17-10-A01	1	86	AS-SIL-10-A01	KA-AG-217	1
16	W17-5-A01	1	87	OB-08-A01	KA-AG-231	1
17	M4-16-07-A01	1	88	AG-119-39-A01	KA-AG-231	1
18	AG-63-31-A01-1	1	89	AG-119-40-A01	KA-AG-231	1
19	AG-63-35-A01	1	90	RAS-49-02-BK-A01	KA-AG-231	1
20	S-R-78-A01	1	91	AS-49-01-BK-A01	KA-AG-231	1
21	M4-16-10-A01	1	92	SCR-HE-2M4X12-A01	KA-AG-231	4
22	IB-135-A01	1	93	RAS-48-P2-A01	KA-AG-231	1
23	AG-63-05-BK-A01	1	94	SCR-HE-0M5X8-A02	KA-AG-231	2
24	AG-63-17-A01	1				
25	P-28-O-A01	1				
26	S-R-79-A01	1				
27	AG-63-12-A01	1				
28	M4-20-17-A01	1				
29	M4-20-19-A01-1	1				
30	S-L-83-A01	1				
31	M4-07-01-A01	1				
32	S-R-80-A01	1				
33	SCR-CR-1M3X6-A01	1				
34	AG-63-16-A01	1				
35	SCR-CR-1-M2X8-A01	1				
36	S-R-84-A01	1				
37	AG-63-09-BK-A01	1				
38	AG-217-01-BK-A01	1				
39	M4-11-02-A01	1				
40	M4-11-03-A04	1				
41	AG-63-15-A01	1				
42	P-30-C-A01	1				
43	AG-63-14-A01	1				
44	AG-63-20-BK-A01	1				
45	S-R-49-A01	1				
46	SCR-CR-1M2D5X3D5-A01	1				
47	AG-217-05-BK-A01	1				
48	AG-217-07-BK-A01	1				
49	S-R-217-07-A01	1				
50	P-C-6X5X15-A01	1				
51	P-C-5X30	1				
52	M4-05-06-A01	1				
53	SCR-CR-3M5X50-A01	1				
54	STOCKP-113-BK-A01	1				
55	STOCKP-112-BK-A01	1				
56	STOCKP-116-BK-A01	1				
57	BOT-1	1				
58	SCR-CR-1M3X8-A01	2				
59	TP-29-06-BK-A01	1				
60	TP-29-07-BK-A01	1				
61	PRT0128-A01-1	1				
62	BSCR-CR-3M3X8-A01	2				
63	S-R-46-A01	1				
64	SCR-HE-1M2x10-A01	1				
65	AG-217-02-BK-A01	1				
66	AG-217-03-BK-A01	1				
67	AG-217-06-BK-A01	1				
68	RAS-75-08-BK-A01	KA-AG-220				
69	RAS-75-06-BK-A01	KA-AG-220				
70	SCR-HE-1M5X10-A01	KA-AG-220				
71	RAS-75-07-BK-A01	KA-AG-220				

Thank you very much for buying King Arms product.

Airsoft Gun, Parts and Accessories Manufacturer

